



PANTHER®

Panther GmbH
Manufacture, Sales and Rental
of Cinematographic Equipment
Raiffeisenallee 3
82041 Oberhaching-Munich
Phone: + 49 (89) 613 900-01
Fax: + 49 (89) 613 1000

SUPER PANTHER III

Operating Instruction



Contents

page

Contents.....	2
Preface	3
Safety guidelines.....	4
Super Panther III diagram	5
Mechanical principles.....	6
Getting started	7
Front panel.....	8
Selector switches.....	9
Driving patterns.....	10
Programming	11
Power supply	12
Charging options.....	13
Steering	14
Wheel legs.....	14
Wheel adjustment	15
Turnstile attachment.....	15
Load tolerances diagram.....	16
Column.....	17
Tracking	18
Maintenance	18
Back up operation.....	19
Technical Specifications.....	20

Preface

Congratulations on choosing the Super Panther III camera support system. The Super Panther III employs state-of-the-art technology to give users optimum performance in the field of camera dollying.

Employing specially selected materials and high quality components, designed around a unique computer-controlled column drive system, the Super Panther III offers you a whole new scope of practical application in studio and location shooting.

The Super Panther III is robust and easy to operate, and yet it enables the cameraman to obtain creative results in steady framing and smooth tracking. The Super Panther III was designed and built by specialist craftsmen for the professional user, in consultation with many expert cameramen and operators.

In its own quiet way, the Super Panther III combines years of experience and workmanship to put a powerhouse of technical progress in the hands of the user.

At Panther, we know you have a right to expect reliable, dramatic results. That's why we created the Panther - so you can create the pictures. Before you do, we'd like you to read our user instruction manual. It contains routine maintenance procedures and all the information you need to set up and operate the Panther safely in every configuration.

Panther GmbH

All inquiries or comments should be addressed to the manufacturer or your local Panther dealer.

Safety Guidelines

1. Do not operate the dolly before these instructions have been read and understood. Safety rules and servicing schedules must be observed.
2. The Super Panther III Dolly may only be operated by qualified personnel. You may participate in one of our workshops which are arranged on request. Certificates are issued for each workshop.
3. The entire operating, panning and lift range of the dolly must be kept clear at all times. Panther GmbH has anticipated the possible risk of squeezes/crushes to some extent by installing deformable fenders and warning signs.
4. Always assemble the system with attention to balance (risk of tilting!). See loading diagrams. Wheel legs must be fully turned out. See wheel legs, p. 12.
5. Note: Do not use the dolly on sloping surfaces or in vehicles. Secure the Super Panther III to prevent rolling. The ground must be stable and unyielding, also when tracks are being used.
6. The column is supported by pneumatic springs which have a high pressure!! If damaged, incorrectly adjusted, or if force has been used, the column may independently move out with great force. Check the drive belt for wear or damage every 6 months or after 100 hours of operation. The belt should be replaced at least every 2 years as a safety precaution. Note: For all maintenance procedures, first extend the column fully to minimize pneumatic pressure. The dolly should only be repaired by technical personnel trained by the manufacturer. Please arrange an appointment for training with Panther GmbH.
7. General electrical guidelines must be observed during electrical operation and maintenance. Protect the equipment from moisture and humidity.

The Super Panther III Dolly

- | | |
|---------------------------------------|--|
| 1. Euro adapter - p. 15 | 9. Motor - p. 4 |
| 2. Turnstile attachment - p. 13 | 10. Battery - p. 10, 11 |
| 3. Friction screw - p. 13 | 11. Steering rod - p. 12 |
| 4. Turnstile attachment brake - p. 13 | 12. Wheel leg - p. 12 |
| 5. Column platform - p. 15 | 13. Steering chain - p. 12, 16 |
| 6. Guide runner - p. 15 | 14. Wheel leg adjustment lever - p. 12 |
| 7. Front panel - p. 6, 7, 8 | 15. Kombi wheel - p. 12, 13, 16 |
| 8. Adjustable seat-extension - p. 13 | 16. Handset - p. 9 |

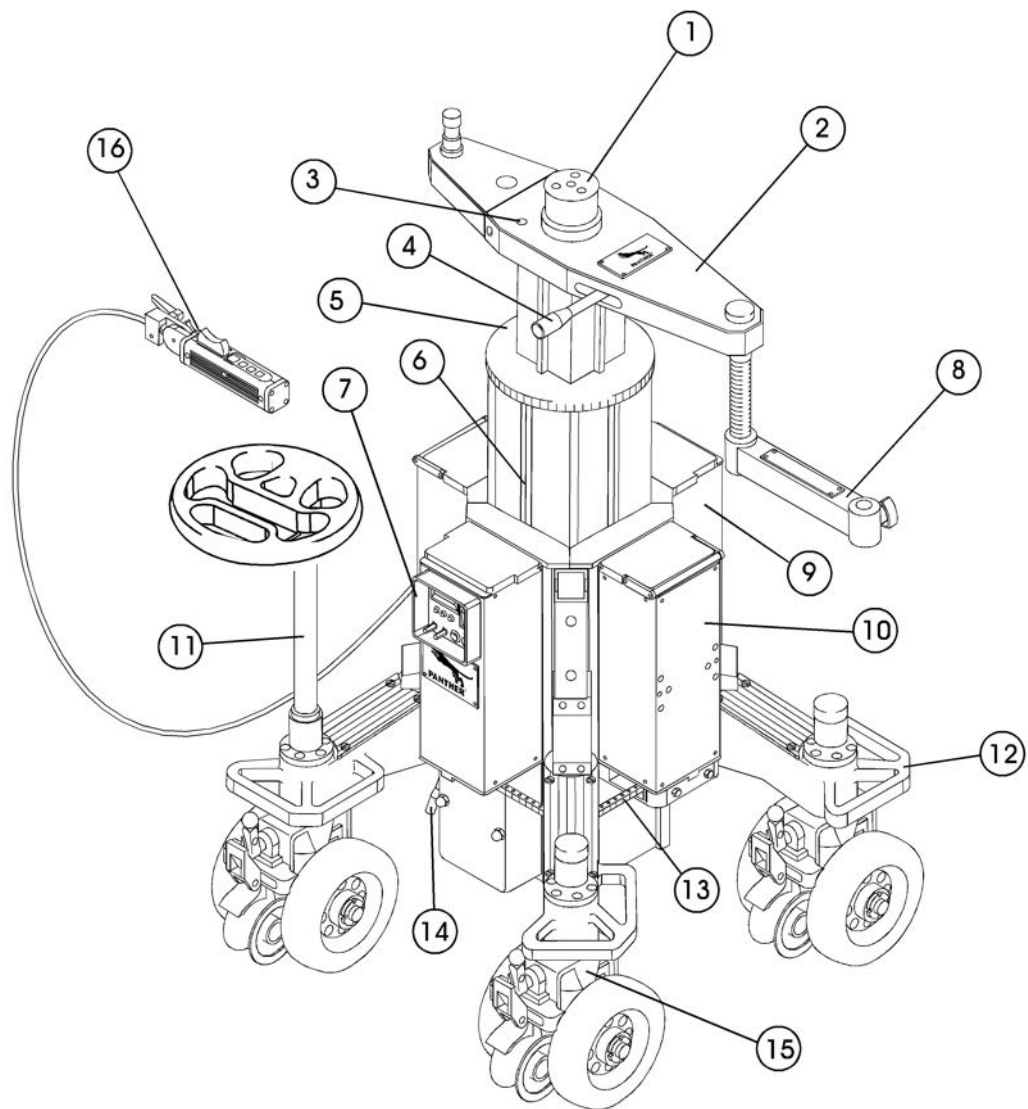

Mechanical Principles

Understanding the Super Panther III dolly's mechanical principles helps to avoid errors in operation. Following is a brief summary of the main points.

The motor is located on the side of the Panther and a special belt-drive transmission rotates the central spindle that drives the column up and down.

The Panther's design combines minimum weight with maximum performance, which is accomplished by a special counter-pressure configuration of 4 pneumatic springs in the base of the column. These springs exert approx. 1.4 kN of upward pressure on the column. When the Panther is switched on, the motor-drive begins working against the weight differential, or balance, of column load minus spring pressure, and holds the column in position. The energy needed by the motor to keep the column stationary is in proportion to the column's load ratio to the spring pressure. Energy consumption is least when load equals pressure, i. e. when the load is approx. 140 kg.

When the Panther is switched off, the column would normally drive upwards or downwards, according to the load. In order to hold the column position when the Panther is switched off, there is a brake situated on the motor shaft that automatically applies spring pressure to the motor shaft as soon as the Panther is switched off.

When the dolly is switched on, the initial stage is the activation of the electronic system only, or stand by condition. The brake remains on until you use the manual control switch on the handset. Then the brake is electromagnetically released, holds the "brake open" position and the motor switches on. At this point, the "brake open" LED on the front panel lights up.

This phase, with electronic system, motor and electromagnetic brake release all activated, is when power consumption is at its maximum. Therefore, when column drive is not required, switch Panther off to conserve power and extend battery life.

If the Panther is left on for a time, but drive system is not used, a secondary system that records the power drag when the brake is released will reapply the brake (a "click" will be heard). Once the brake is on, the Panther is back in stand by mode and the motor shuts down. The "brake open" LED will no longer be lit.

Once the manual control switch is pressed, the system is reactivated: the brake is released and the motor operates to hold the column in position.

If the "click" you hear whenever the brake is released or reapplied should disturb location sound recording, operate the manual control switch before shooting begins. This resets the secondary system, and you have the full time (depending on the load) until the next "click" (brake activation).

Note:

When you turn the Super Panther III dolly on, the system is in "stand by" mode.

The brake is released after either pressing the manual control switch on the handset or when recalling a program.

When column drive is not being used, a secondary system will operate the brake after 120 seconds.

Getting Started

1. Before switching the Panther on, make absolutely sure that the entire lift, panning and operating range of dolly and accessories is clear.
2. Supply the dolly with electricity as described in "Power Supply" p. 10, 11. Note: Please fully comply with instructions.
3. Check if handset, cable and dolly are properly connected.
4. Set the switches on front panel (7) as desired (see "Front Panel", p. 6, 7, 8).
5. Turn the Panther on at the main switch. The control LED "POWER" on the front panel will light up, showing that the Panther is on. Make sure the battery (batteries) is (are) fully charged. You can keep the main switch "on" due to the "On-Off" - switch located on the handset (16) which enables you to switch the dolly "on" or "off".
The Dolly does not turn on if one of these two switches is off.
6. Using the handset (16), bring the column to the desired position. Press the manual control switch forward to elevate the column, pull back to lower the column. This switch also determines the speed of travel, according to the pressure used.
Note: When not using the column lift, switch the Panther off to conserve battery power.
The Super Panther has a "On-Off" - switch located on the handset, next to the manual control switch (red knob). This switch is used to stop the elevating mechanism during unintentional movements.
The Super Panther III may not be operated with mains power units + chargers sold before 1 January, 1996.

Front Panel

The ergonomically designed front panel displays all information at a glance and enables direct control of operating parameters such as speed, ramp setting etc.

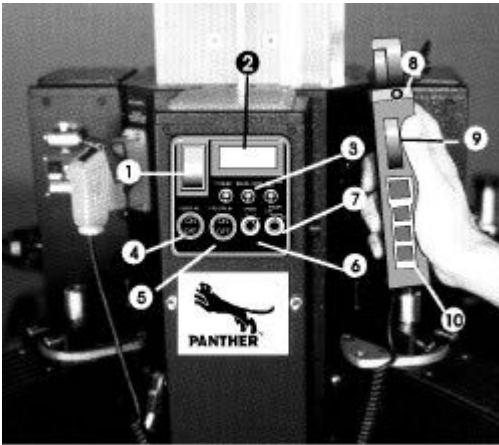

1. On/off switch (with automatic cut-out)
2. LCD display
3. Control LEDs
4. Super Jib operation on/off
5. Handset programming on/off
6. Speed selector
7. Ramp selecting switch
8. "POWER OFF" safety switch
9. Manual control switch
10. Storage/recall keys for programmed movements

The manual control switch (9) is applicable for column movements in both directions and at any speed. More than 250 column movements can be programmed at any position or speed and recalled at will by using the storage/recall keys (10). The manual functioning is nevertheless maintained. The position accuracy leaves nothing to be desired.

MAIN SWITCH
(on/off switch):

Combination of power on/off, safety power off switch on handset and fuse (that will switch off at a constant current exceeding 10 A).

LCD-DISPLAY:

shows the momentary motor voltage (with one battery approx. 24 V, with two batteries approx. 48 V)

CONTROL LEDs:

Power

yellow LED; will light up when the dolly is turned on

Brake open



green LED; will light up when the brake is open. If the dolly is not in operation for longer than 120 seconds, the brake will close automatically and the LED will go out.

Battery empty/error

red LED; will light up when batteries are empty. The LED will start blinking in case of an error. The error can be determined by removing the electronics cover and looking at the display on the left side of the electronics housing:

- | | |
|---------------|--------------------------------|
| b. (on) | battery empty |
| d. (blinking) | fault at rotary encoder |
| E (blinking) | fault at end switch |
| H. (blinking) | fault at handset |
| L (blinking) | current exceeding normal value |

SELECTOR SWITCHES

<p>SUPER-JIB</p> 	<p>Position on:</p> <p>Position off:</p>	<p>Movements with Super Jib (all start and stop ramps are smoother/adapted to Super Jib operation)</p> <p>Standard movements (start and stop ramps are adapted to standard operation).</p>
<p>PROGRAM</p> 	<p>Position on:</p> <p>Position off:</p>	<p>Programming keys on handset are activated. (Note: take care against unintentional operation, see "Programming", p. 10.)</p> <p>Standard travelling (programming keys on handset without effect)</p>
<p>SPEED</p> 	<p>Position 1:</p> <p>Position 2:</p> <p>Position 3:</p> <p>Position 4:</p>	<p>speed 0 ... 25 %</p> <p>speed 0 ... 50 %</p> <p>speed 0 ... 75 %</p> <p>speed 0 ... 100 % (maximum speed)</p> <p>When using only one battery, all column movements are effected at half the speed of the selected position</p>

Acceleration and deceleration phases of the Panther column can be adjusted with the ramp selecting switch.

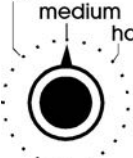
<p>RAMPS</p> 	<p>soft ramp:</p> <p>hard ramp:</p> <p>medium ramp:</p>	<p>acceleration very soft, hardly perceivable</p> <p>strong acceleration to maximum speed, strong deceleration until stopping</p> <p>characteristic between soft and hard</p>
---	---	---

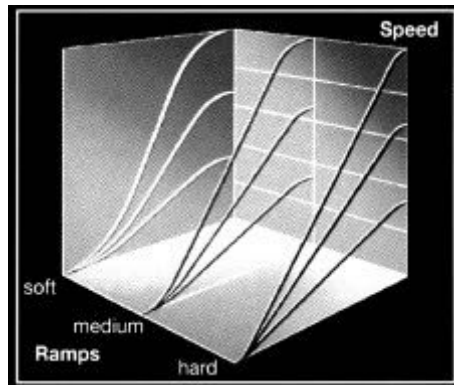

The start and stop ramps are programmed in our factory. Speed selector 1,2,3,4 and Super Jib on/off switch change the start and stop ramps according to the selected requirements.

Note: At all ramp settings (soft, medium and hard), but especially at "soft", the Panther column will still move somewhat after the handset's manual control switch (9) is released: risk of crushing!
Observe safety distances. If there is any danger of crushing, press the "power off" safety switch on handset. Also see "Operation/Safety Precautions Super Jib I and II".

Programming

- a) Set "Program" switch on front panel to "on". Use manual control switch to select the column height that will serve as starting point. Press the key marked SIF to enter the first point (starting point) in the program memory. (When SIF is pressed, only the starting point is memorized, and any existing programs are erased.)
- b) Use the manual control switch to bring the column to the next desired point (= first stopping point). The Panther electronics will memorize only the highest speed used to reach this point manually, and will repeat the move at this speed throughout. If you wish to program a slower movement, you must drive slowly to the stopping point.
- c) You may drive up or down to any stopping point until it is entered. Enter the point by pressing STM.
Note: Stopping point will only be recorded when the column is completely stationary. To be quite sure of correct entry of any point, always wait a moment before pressing STM.
- d) Move to the second stopping point and enter it by pressing STM. Any of up to 255 stopping points are entered by always pressing STM.
- e) Before recalling or resetting the program in sequence, move to the starting point by pressing GRF. The column automatically returns to this point at the maximum speed chosen with the speed selector.
- f) To recall the program, press A (Action) for every movement in chronological order.

Note: For safety reasons, set "program" switch on the front panel to "off" when not using programming mode. This will not erase programmed movements; these are reactivated when "program" switch is set to "on".

Power Supply

The Super Panther III dolly can be supplied with power as shown on the diagrams below. Should your Super Panther III dolly be equipped with a snap-on mains power unit + charger (SN), please read "Operating instructions for Snap-On Mains Power Unit + Charger" before operation.

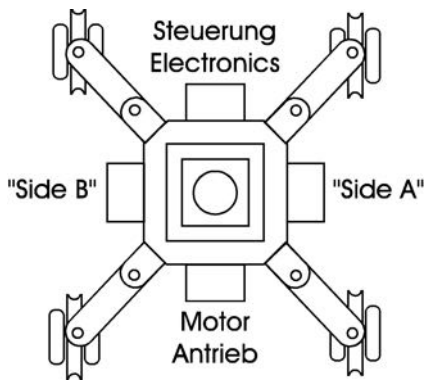

- B = battery
- SN = snap-on mains unit + charger
- 24 V = single speed
speed selector switch setting 2
(speed 2)
- 48 V = double speed
speed selector switch setting 4 (speed 4)

Power Supply Options

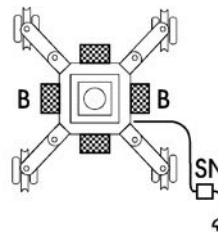
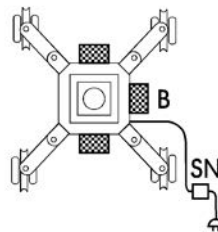
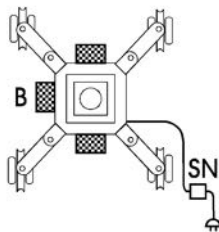
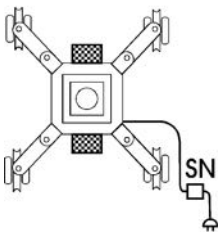
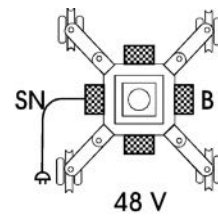
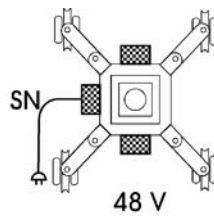
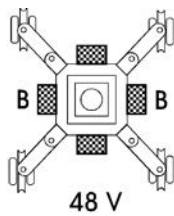
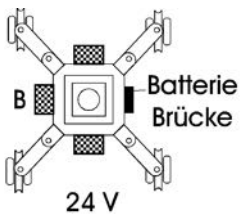

Charging Options

- B= battery
- SN = snap-on mains unit + charger
- ZL = extra charger for 1 or 2 batteries

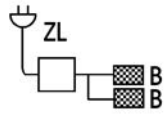
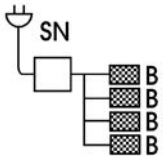
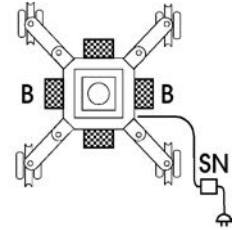
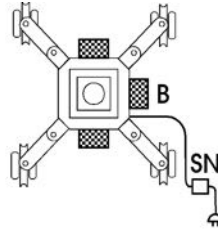
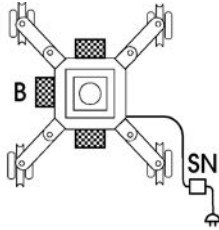
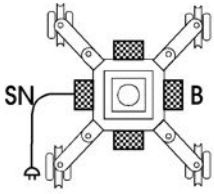

Steering

Symmetrical configuration of 4 identical wheel legs enables 1-wheel, 2-wheel and 4-wheel steering (crab & steer) from all 4 sides.

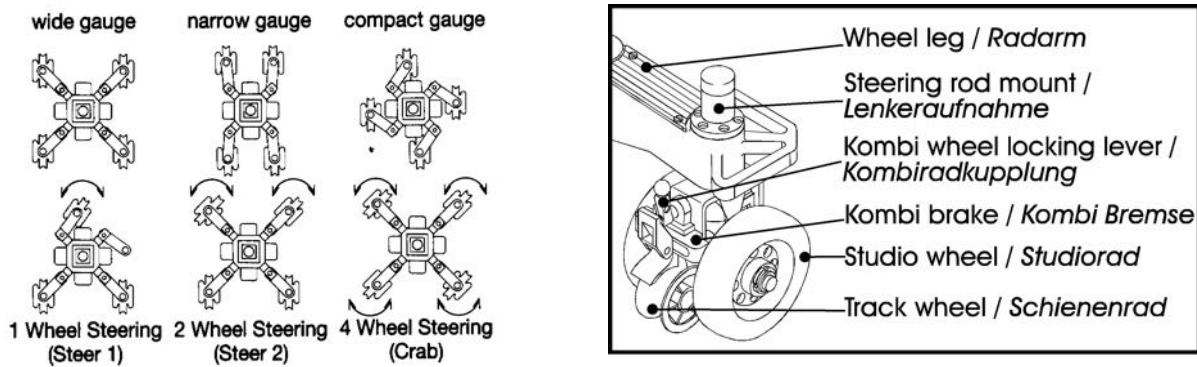

1-wheel steering

Disengage the locking levers on two adjacent kombi wheels and align them using the accessory wheel locking bar (order # 100514 or # 100522). Remove the fourth kombi wheel. For safety reasons, the Super Panther III dolly may not be loaded laterally (risk of tilting!)

2-wheel steering

Disengage the locking levers on two adjacent kombi wheels and align them using the accessory wheel locking bar (order # 100514 or # 100522). Connect the accessory steering transmission rod (order # 100473 or # 100521) to the remaining - steering - wheels, one of which is disengaged using the kombi wheel locking lever. The steering transmission rod attaches to the wheels in the kombi brake notches. The steering rod may be attached to one of the sockets located above a steering kombi wheel.

4-wheel steering

The vertical axles of all four kombi wheels are connected to the steering chain. The steering rod may be attached to any of the steering sockets.

Note:

For safety reasons, the Super Panther III dolly may not be loaded laterally when using 1-wheel steering, narrow gauge or compact gauge configuration (risk of tilting!).

Wheel legs

In order to set a wheel leg configuration, press down the leg adjustment lever (14) to unlock the individual wheel position. The lever should click back into place after release, but check that it locks securely to be quite sure.

When using a jib arm or outrigger, always use wide gauge wheel configuration. Always pay attention to load tolerances (see "Load tolerances diagram").

Wheel adjustment

It can happen that a wheel or wheels get knocked out of position in transport, by misuse or use of force. This section deals with realigning and adjusting wheels.

Loosen the steering axle pivot screws on all four kombi wheels. (The pivot screw is located in a deep bore in the kombi wheel carrier.) Turn the wheels until the kombi wheel clutch levers for the front wheels are pointing forwards, and the rear levers pointing backwards (see diagram).

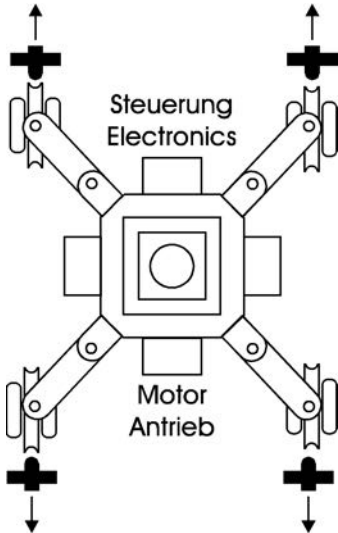

Align two wheels at a time using the wheel locking bar (wheels side by side) or the side locking bar (one wheel behind the other) and secure the pivot screws; then, the next two wheels, and so on.

Turnstile Attachment

The turnstile attachment rotates on a ball bearing. Friction of rotation can be varied using the friction screws.

The entire turnstile can be fixed in any setting using the brake.

The extension bracket for the second seat (focus-puller) can be dismantled by undoing the 2 Allen screws on either side.

The camera operator's seat should not be extended, as this could result in damage to the threaded seat-extension rod.

Load Tolerances Diagram for Super Panther III

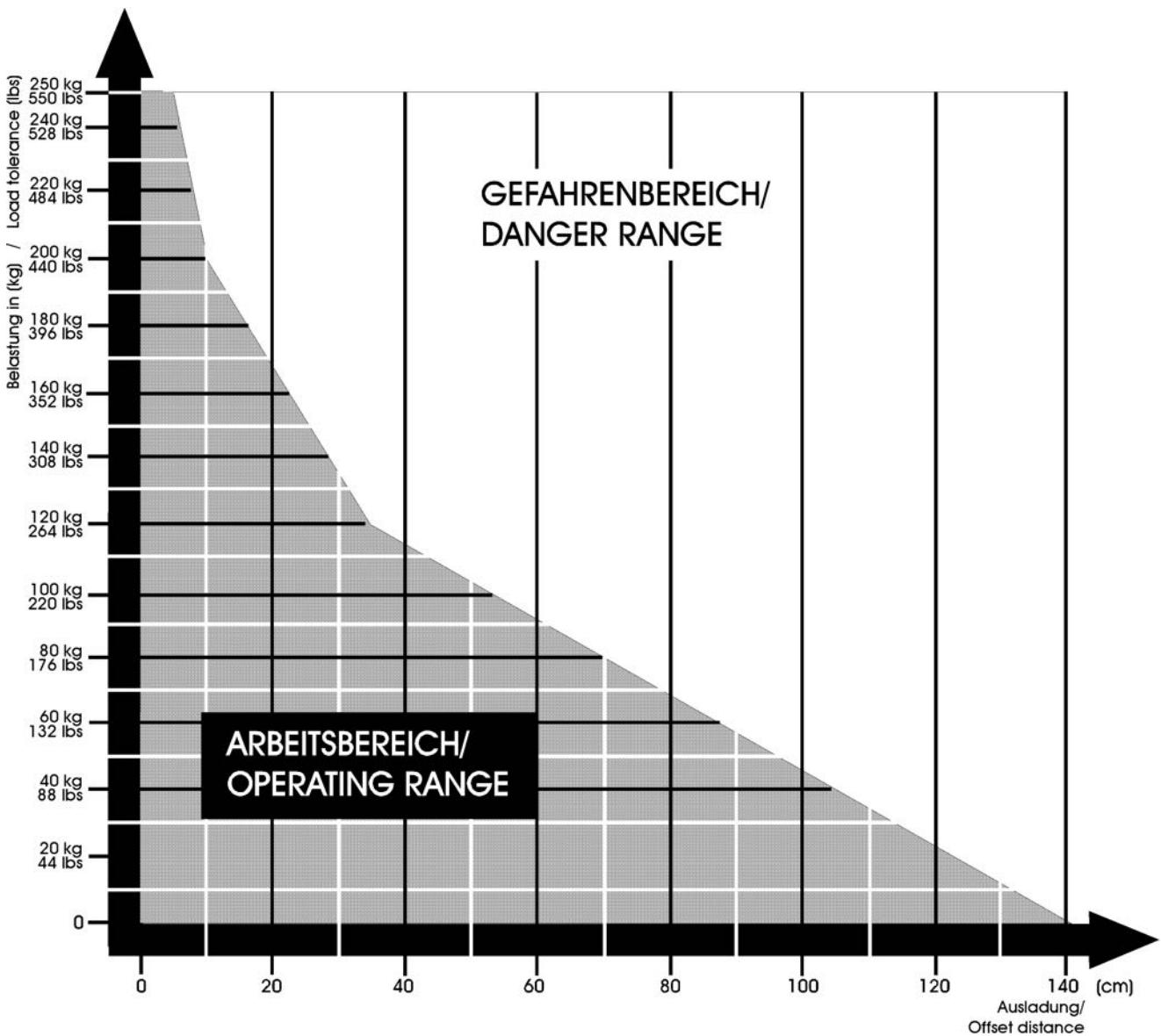

When using the Super Panther III with outriggers (e. g. outrigger III, U-Bangi), always use wide gauge wheel configuration for safety reasons (p. 12). The load tolerances diagram must be adhered to.
 maximum central column load: 250 kg / 550 lbs
 maximum offset distance: 140 cm

A counterbalance rod (order # 100503) can be used to increase stability. The rod is installed at the side opposite the lateral column load and the according number of counterweights attached. In this case, the outrigger (e. g. outrigger III, U-Bangi) may not be rotated! When using Panther jib arms (e. g. Super Jib II), observe the corresponding load tolerance diagrams.

Column

Mid-way on the column there is a small platform, intended as a footrest for the camera operator. The platform has a fail-safe breakage point built in, so that serious injuries will not occur. If the operator's foot happens to be under the platform while the column is being retracted, the platform is designed to break.

The column is guided by runners between bearings. The column guide runners should be kept free of dust or grit but never oiled. (Oil might cause the incremental rotary encoder to slip against the guide runner and this would result in misreading of drive parameters and uncontrolled column lift movements.)

The small column (on which the euro adapter is mounted) should never be pulled upwards, as the internal steel cables would slacken and possibly kink. Please be especially careful when taking off a jib arm. The jib arm could cant with the euro adapter and when lifting the jib arm the column would then be pulled out, too.

What is unique in the patented column guiding system of PANTHER® ...?

... the redirection of a high lateral column load into an almost vertical load!

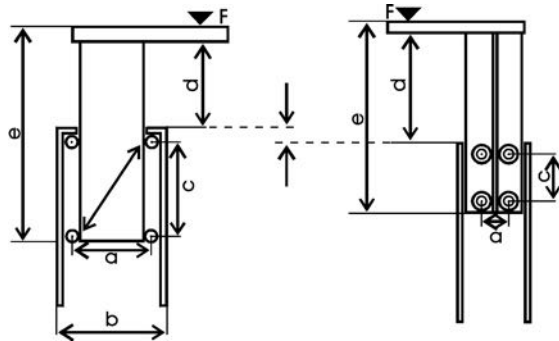

The advantages of the PANTHER® column are demonstrated by direct comparison of columns A and B (see diagram):

- The roller bearing's diameter is increased, due to its position against the column
Advantage 1: larger and stronger roller bearings
Advantage 2: fewer revolutions, i. e. quieter and longer-lasting bearings
- The horizontal distance between the roller bearings (a) can be kept very small, due to the guide runner.
Advantage 3: more compact and lighter construction (b)
Advantage 4: very steep (almost vertical) vector of force, i. e. little pressure on guide rails? stronger column unit, higher lateral loading capacity!
- The vertical distance of the roller bearings (c) can also be kept small due to this patent.
Advantage 5: lower camera position (dotted line)
Advantage 6: more column lift range (d) at same column length (e)
Advantage 7: The PANTHER® column is maintenance-free. Adjustment of roller bearings is not required.

Tracking

The Super Panther III Dolly can be operated on wide gauge (62 cm) tracks and narrow gauge (36 cm) tracks. The wheel gauge is adapted to the track gauge (p. 12). All four kombi wheels are unlocked from the steering chain before tracking (p. 12), otherwise the dolly could derail (especially on curved tracks). If there is a high column payload, the standard track wheels should be exchanged with hard track wheels. This will prevent possible damage to the standard track wheels and lower frictional resistance.

Always select wide gauge tracking when using jib arms or outriggers. Always observe load tolerances diagram.

Maintenance

Maintenance should only be effected by trained personnel that is familiar with the Super Panther III mechanics. The Super Panther III is, generally speaking, a maintenance-free dolly that will work soundly and reliably.

In order to ensure a long life and constant quality, the specified servicing intervals should be observed.

A competent person should check all elements relevant to safety and functioning when the need arises, but at least every 6 months, according to ZH 1/222 para. 3.2 or UVV VBG 70 §14/2, and exchange them if necessary.

Following elements should be checked regarding function and wear:

Spindle nut	free from play or little play (exchange if needed, but at least every 6 month)
Drive belt	when lightly pressed approx. 10 mm
Pneumatic springs	approx. 700 N
Steel cables	to be replaced according to DIN 15020 part 2 (e. g. no kinks)

Please see our video tape "Service Instructions" for further information on checking/adjusting these elements.

Check wheel leg attachments and wheel leg adjustment levers for correct locking, and repair if necessary.

The motor brake tolerance is 0.4 mm - adjust if necessary.

Check battery voltage regularly. Battery cells should be exchanged approx. every 2 years.

Column guide runners and roller bearings should always be free of grease. They should be cleaned (e. g. with alcohol) after shooting has finished for the day.

Back up Operation

In the event of malfunction or breakdown of the Panther's electronic system, the column can be elevated or retracted mechanically.

Procedure:

1. When being retracted, the column must be loaded with approx. 180 kg. When being elevated, the column must be relaxed (< 140 kg).
2. At the same time, the motor brake must be kept open. Two screw drivers are of practical help in countering the brake disk's spring pressure. In case of any uncertainty, please see our video tape "Service Instructions".

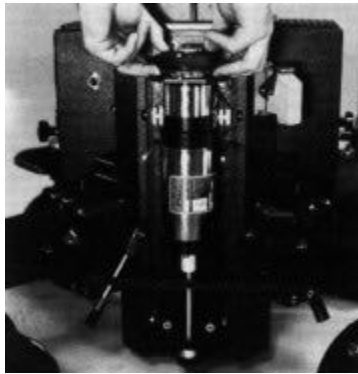

Technical Specifications

Weight.....	123 kg (271 lbs)
minimum height.....	69 cm (27 1/4")
maximum height.....	138 cm (54 3/10")
lift range.....	69 cm (27 1/4")
lifting capacity.....	300 kg (661 lbs)
maximum column load capacity with retracted column.....	1000 kg (2,204 lbs)
maximum column load capacity with elevated column.....	500 kg (1,102 lbs)
column lift v max.	3.6 sec.
sound level.....	28 dB- 32 dB
wind load max.	40 km/h (24.86 mph)
columns.....	2
pneumatic springs.....	2
wheel legs.....	4
wide gauge track.....	62 cm (24 2/5")
narrow gauge track.....	36 cm (14 1/4") - not permissible for Super Jib II operation, see p. 13!

Motor

DC servo-motor.....	d. c. electric motor with tachometer
torque at rated load.....	1.00 Nm
rated current.....	7.5 A
rated speed.....	4000 Min ⁻¹
tension constant.....	14 V/1000 Min ⁻¹
torque constant.....	0.133 Nm/A
motor brake.....	DC 24 V
motor brake play.....	0.4 mm